

# Reach-In Blast Chiller / Shock Freezer MultiFresh Model EF 20.1

## EF 20.1

... YOUR TRUSTED KITCHEN ASSISTANT

The **IRINOX Model EF 20.1 Blast Chiller / Shock Freezer** shall have the following characteristics: Capacity – (8) 18"x13" half size sheet pans or (4) 12"x20"x2-1/2" steam table pans or (6) gelato pans. Controller shall feature four (4) standard modes for chilling or freezing. Core probe – product core temperature probe with "easy-out" feature; plus all the standard features listed below.



Model EF 20.1

Item No. \_\_\_\_\_

Qty. \_\_\_\_\_

Project \_\_\_\_\_

\_\_\_\_\_

\_\_\_\_\_

\_\_\_\_\_

\_\_\_\_\_

### Standard Construction Features:

- All type 304 stainless steel construction
- CFC-free high-density polyurethane insulation
- Full width door with low-temperature resistant magnetic gasket
- Die-stamped interior door liner to magnetically store core probe
- Removable stainless steel pan supports, adjustable spacing
- Integrated single compressor and condenser
- Approved R404 refrigerant used in sealed system
- High efficiency evaporators with multiple injection points
- Magnetic lock front grille and magnetic coil filter for easy condenser cleaning
- Luminous display and smudge-resistant touch pad controls
- Door hinged left (standard)
- 4" stainless steel height-adjustable legs
- End-of-cycle hold mode
- Self-contained, air-cooled energy efficient condenser

### Sizing & Unit Production Guide EF 20.1

Capacity: (12"x20"x2-1/2") steam table pans	4
Capacity: (18"x13") half size sheet pans	8
Capacity: 5-liter gelato pans	6
Pan Spacing:	adjustable; factory set at 2-3/4"
Blast Chilling Capacity (194F to 37F)*:	44 lbs
Shock Freezing Capacity (194F to 0F)*:	44 lbs

\* Per production cycle (depending on product density):  
 Blast chilling ... up to 90-minute cycle  
 Shock freezing ... up to 240-minute cycle

### Unique Design and Performance Features:

- Four (4) cycles in standard mode: two (2) for chilling to + 37 F and two (2) for freezing to 0 F
- 30-40% more energy efficient, with faster chilling times - all while preserving the freshness and fragrance of the food
- Indirect air distribution and special airflow pattern to ensure perfect temperature uniformity
- Moisture preservation system by "delta-t" control
- Smudge-resistant controller touch pad
- Easy access to washable evaporators, waterproof fans, removable magnetic condenser filter

### Options and Accessories (Please check):

- Door hinged right
- 4" swivel casters, two (2) with locks
- SANIGEN sanitation system
- Remote, air-cooled condenser
- Self-contained, water-cooled condenser
- Portable HACCP Data printer

### Product Warranty Protection:

- 1 year, parts and labor
- 5 year, compressor

Operating Modes:	Temperature Drop (F)*	Time **	Product Applications:
Standard Mode – Delicate to +37F	+194F to +37F	90 min or less	Delicate or thin food items
Standard Mode – Strong to +37F	+194F to +37F	90 min or less	High density, bulky or packaged food items
Standard Mode – Delicate to 0 F	+194F to 0 F	240 min or less	Hot cooked or delicate food items
Standard Mode – Strong to 0 F	+194F to 0 F	240 min or less	Raw, chilled or thin cooked food items

\* Core product temperature \*\* Actual times based on product density and temperature



IRINOX USA 31 Eastman Street, South Easton, MA 02375  
 Phone: 508-230-5818 Fax: 508-230-5819 www.irinoxusa.com email: info@irinoxusa.com

# EF 20.1

**...YOUR TRUSTED KITCHEN ASSISTANT**

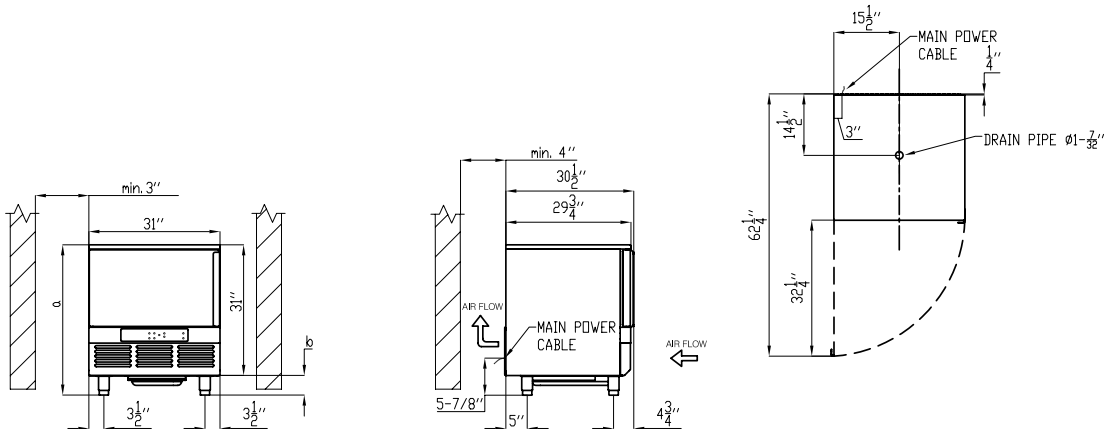

## Equipment Dimensions and Weight

Width	31"
Depth	30-1/2"
Height w/legs	34-1/4"
Height w/casters	35-1/4"
Weight	315 lbs
Capacity: (12"x20"x2-1/2") steam table pans – at 2-3/4" pan spacing	4
Capacity: (18"x 13") half size sheet pans – at 2-3/4" pan spacing	8

## Installation Notes:

1. Compressor requires 4" minimum rear wall clearance or 3" right and left clearance

## Key Refrigeration System Data

Compressor rating (HP)	0.5
Refrigeration Yield (14/+104F) (BTU/HR)	5,543
Condenser Yield (14/+104F) (BTU/HR)	8,697
Refrigerant Type / Nominal Refrigerant Charge (lbs)	R404A / 3.97
Maximum Ambient Temperature (F)	90

**[D] Drain Connection:** 1-1/4" ID [Per local codes]

## Electric Data / Power Requirements

208V 60 Hz 1 Phase	Total Rating: 1.3 HP
208V 60 Hz 1 Phase	Amp Draw: 6.4 A
NEMA Plug Configuration	L6-15P

Continued product development may necessitate specification changes without notice.



Rev. 12/10



IRINOX USA 31 Eastman Street, South Easton, MA 02375

Phone: 508-230-5818 Fax: 508-230-5819 www.irinoxusa.com email: info@irinoxusa.com