

Reach-In Blast Chiller / Shock Freezer MultiFresh Model MF 30.2

MF 30.2

... YOUR TRUSTED KITCHEN ASSISTANT

The **IRINOX Model MF 30.2 Blast Chiller / Shock Freezer** shall have the following characteristics: Capacity – (4) 18"x26" full size sheet pans or (8) 12"x20"x2-1/2" steam table pans; controller - shall feature the following control paths: standard mode for chilling or freezing, dynamic mode for chilling or freezing (icon driven) and personalized modes for customer specific products; core probe multi-sensor product core temperature probe with five (5) measuring points and "easy-out" feature; plus all the standard features listed below.

Standard Construction Features:

- All type 304 stainless steel construction
- CFC-free high-density polyurethane insulation
- Full width door with low-temperature resistant magnetic gasket
- Die-stamped interior door liner to magnetically store core probe
- Ergonomic stainless steel door handle
- Removable stainless steel pan supports, adjustable spacing
- Integrated single compressor and condenser
- Approved R404 refrigerant used in sealed system
- High efficiency evaporators with multiple injection points
- Magnetic lock front grille and magnetic coil filter for easy condenser cleaning
- Luminous display with intuitive work-path controls
- Thawing cycle and proofing cycle
- USB port for data transfer to HACCP software, internal software upgrades and individual program uploads
- Door hinged left (standard)
- 4" stainless steel height-adjustable legs
- End-of-cycle hold mode
- Air-cooled, self-contained energy efficient condenser



Model MF 30.2

Item No. _____

Qty. _____

Project _____

Sizing & Unit Production Guide MF 30.2

Capacity: (12"x20"x2-1/2") steam table pans	8
Capacity: (18"x26") full size sheet pans	4
Pan Spacing:	adjustable; factory set at 2-3/4"
Blast Chilling Capacity (194F to 37F)*:	66 lbs
Shock Freezing Capacity (194F to 0F)*:	66 lbs
* Per production cycle (depending on product density): Blast chilling ... up to 90-minute cycle Shock freezing ... up to 240-minute cycle	

Unique Design and Performance Features:

- 4 cycles in standard mode, 39 product specific cycles in dynamic mode; ability to record up to 20 replicable cycles into customized recipe book
- 30-40% more energy efficient, with faster chilling times - all while preserving the freshness and fragrance of the food
- Electronically controlled fans with automatic speed variation, low power consumption; open-door auto stop feature
- Indirect air distribution and special airflow pattern to ensure perfect temperature uniformity
- Moisture preservation system by "delta-t" control
- Smudge-resistant controller touch pad
- Easy access to washable evaporators, waterproof fans, removable magnetic condenser filter

Options and Accessories (Please check):

- Sous-vide pouch core temperature probe
- Prison package
- Door hinged right
- 4" swivel casters, two (2) with locks
- SANIGEN sanitation system
- Remote, air-cooled condenser
- Self-contained, water-cooled condenser
- Portable HACCP data printer
- HACCP software

Product Warranty Protection:

- 1 year, parts and labor
- 5 year, compressor

Operating Modes:	Temperature Drop (F)*	Time **	Product Applications:
Standard Mode – Delicate to +37F	+194F to +37F	90 min or less	Delicate or thin food items
Standard Mode – Strong to +37F	+194F to +37F	90 min or less	High density, bulky or packaged food items
Standard Mode – Delicate to 0 F	+194F to 0 F	240 min or less	Hot cooked or delicate food items
Standard Mode – Strong to 0 F	+194F to 0 F	240 min or less	Raw, chilled or thin cooked food items
Dynamic Mode (Icon Driven) to +37F	+194F to +37F	Set times***	Specific product categories
Dynamic Mode (Icon Driven) to 0 F	+ 194 F to 0 F	Set times***	Specific product categories

* Core product temperature ** Actual times based on product density *** Actual times set by Icon Product Code



IRINOX USA 31 Eastman Street, South Easton, MA 02375

Phone: 508-230-5818 Fax: 508-230-5819 www.irinoxusa.com email: info@irinoxusa.com

MF 30.2

...YOUR TRUSTED KITCHEN ASSISTANT

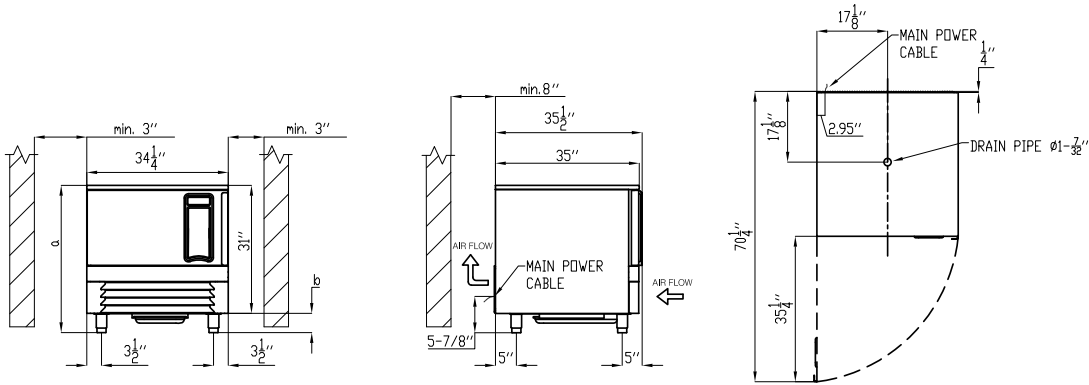

Equipment Dimensions and Weight

Width	34-1/4"
Depth	35-1/2"
Height w/legs	34-1/4"
Height w/casters	35-1/4"
Weight	390 lbs
Capacity: (12"x20"x2-1/2") steam table pans – at 2-3/4" pan spacing	8
Capacity: (18"x 26")full size sheet pans – at 2-3/4" pan spacing	4

Installation Notes:

1. Compressor requires 8" minimum rear wall clearance and 3" right and left clearance,

Key Refrigeration System Data

Compressor rating (HP)	1.0
Refrigeration Yield (14/+104F) (BTU/HR)	11,349
Condenser Yield (14/+104F) (BTU/HR)	17,711
Refrigerant Type / Nominal Refrigerant Charge (lbs)	R404A / 4.0
Maximum Ambient Temperature (F)	90



[D] Drain Connection: 1-1/4" ID [Per local codes]

Electric Data / Power Requirements

208V 60 Hz 1 Phase	Total Rating: 3.0 HP
208V 60 Hz 1 Phase	Amp Draw: 11.7 A
NEMA Plug Configuration	L6-20P

Continued product development may necessitate specification changes without notice.

Rev. 12/10



IRINOX USA 31 Eastman Street, South Easton, MA 02375

Phone: 508-230-5818 Fax: 508-230-5819 www.irinoxusa.com email: info@irinoxusa.com